

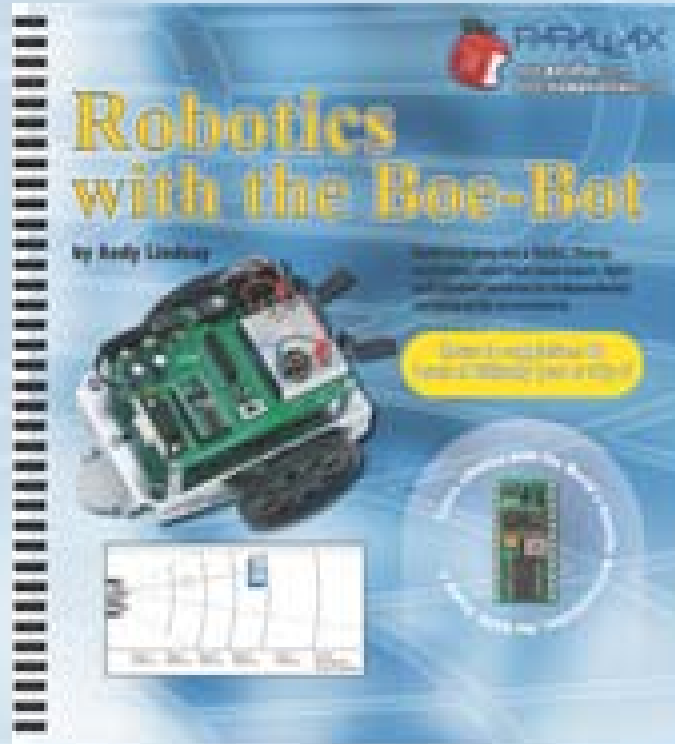

Robotics: with the Boe-Bot



Presentation based on:

“Robotics: with the Boe-Bot”

by Andy Lindsay

PARALLAX 

www.parallax.com

599 Menlo Drive

Suite 100

Rocklin, CA 95765



Copyrights and Trademarks

This documentation is copyright 2004 by Parallax, Inc. By downloading or obtaining a printed copy of this documentation or software you agree that it is to be used exclusively with Parallax products. Any other uses are not permitted and may represent a violation of Parallax copyrights, legally punishable according to Federal copyright or intellectual property laws. Any duplication of this documentation for commercial uses is expressly prohibited by Parallax, Inc. Duplication for educational use is permitted subject to the following conditions: Parallax grants the user a conditional right to download, duplicate, and distribute this text without Parallax's permission. This right is based on the following conditions: the document, or any portion thereof, may not be duplicated for commercial use; it may be duplicated only for educational purposes when used solely in conjunction with Parallax products, and the user may recover from the student only the cost of duplication.

BASIC Stamp, Stamps in Class, and Board of Education are registered trademarks of Parallax, Inc. If you decide to use the names BASIC Stamp, Stamps in Class, and/or Board of Education on your web page or in printed material, you must state that "BASIC Stamp is a registered trademark of Parallax, Inc.," "Stamps in Class is a registered trademark of Parallax, Inc.," and/or "Board of Education is a registered trademark of Parallax, Inc.," respectively, upon the first appearance of the trademark name. Other brand and product names are trademarks or registered trademarks of their respective holders.



Introducing the Continuous Rotation Servo

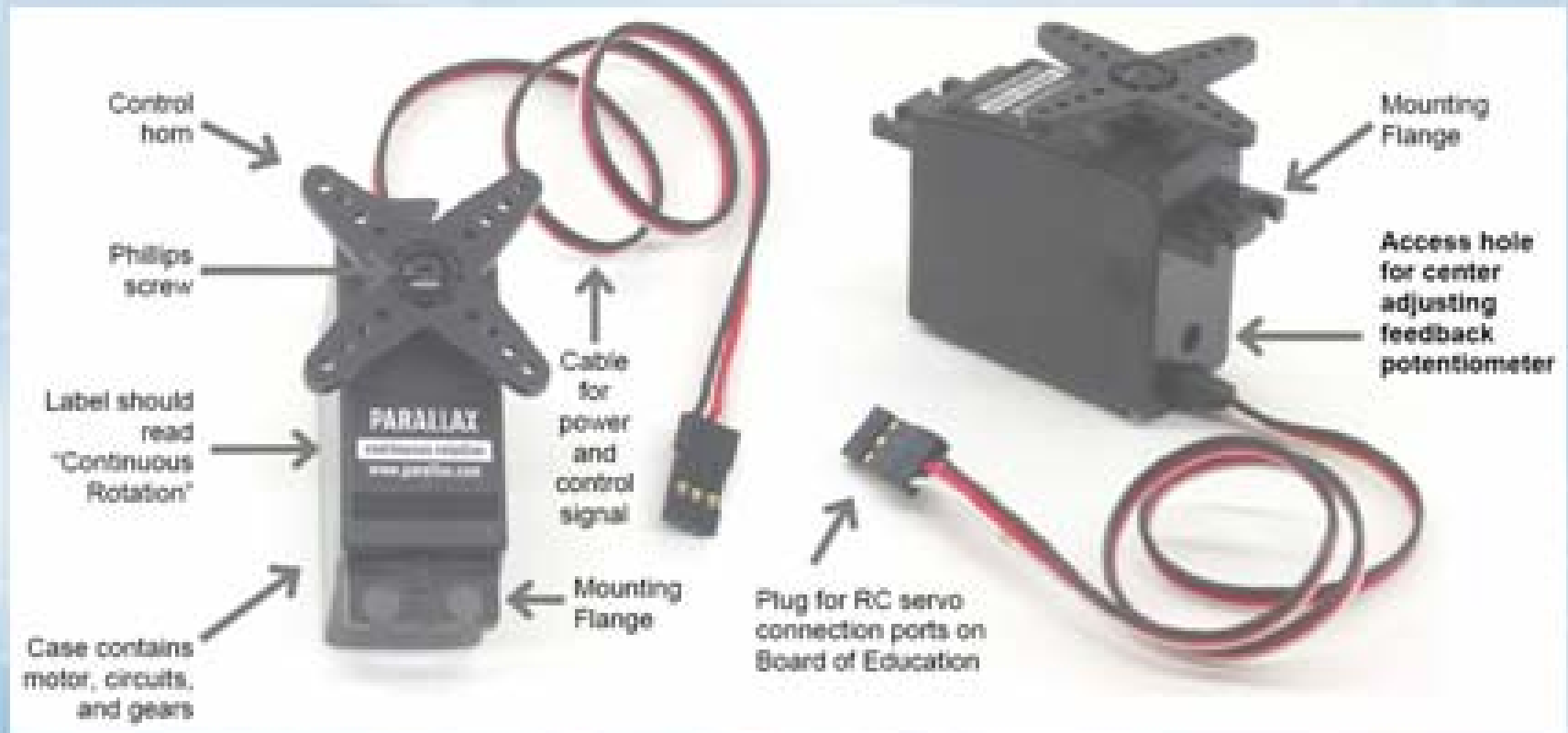



Connecting Servos to the Board of Education Rev C

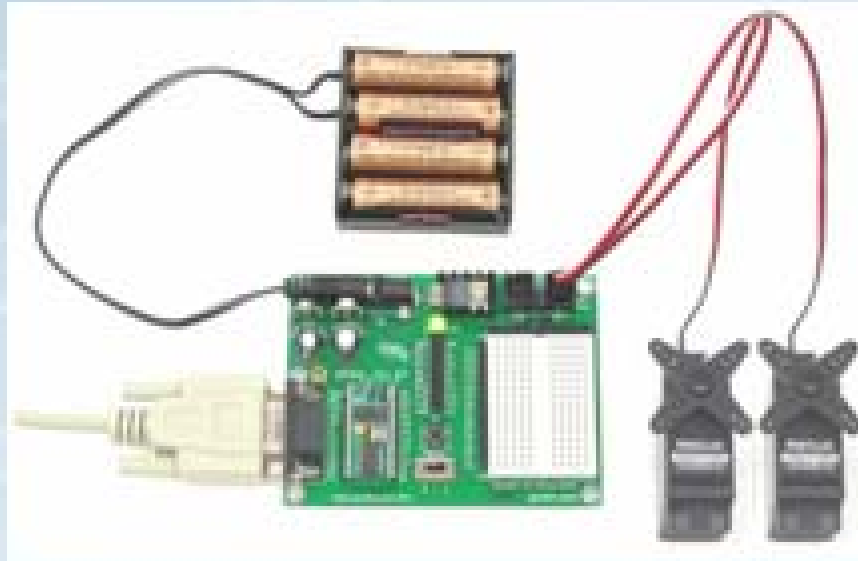



Connecting Servos to the Board of Education Rev C



Page 60

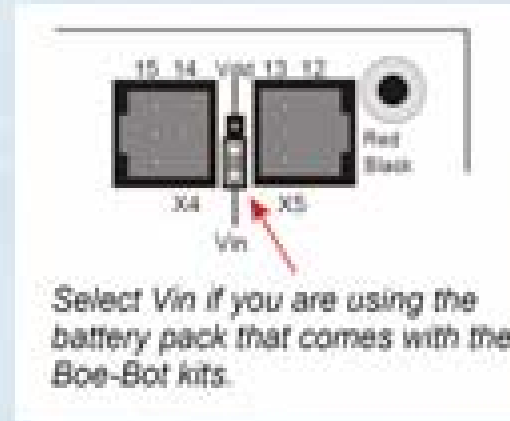

Page 61

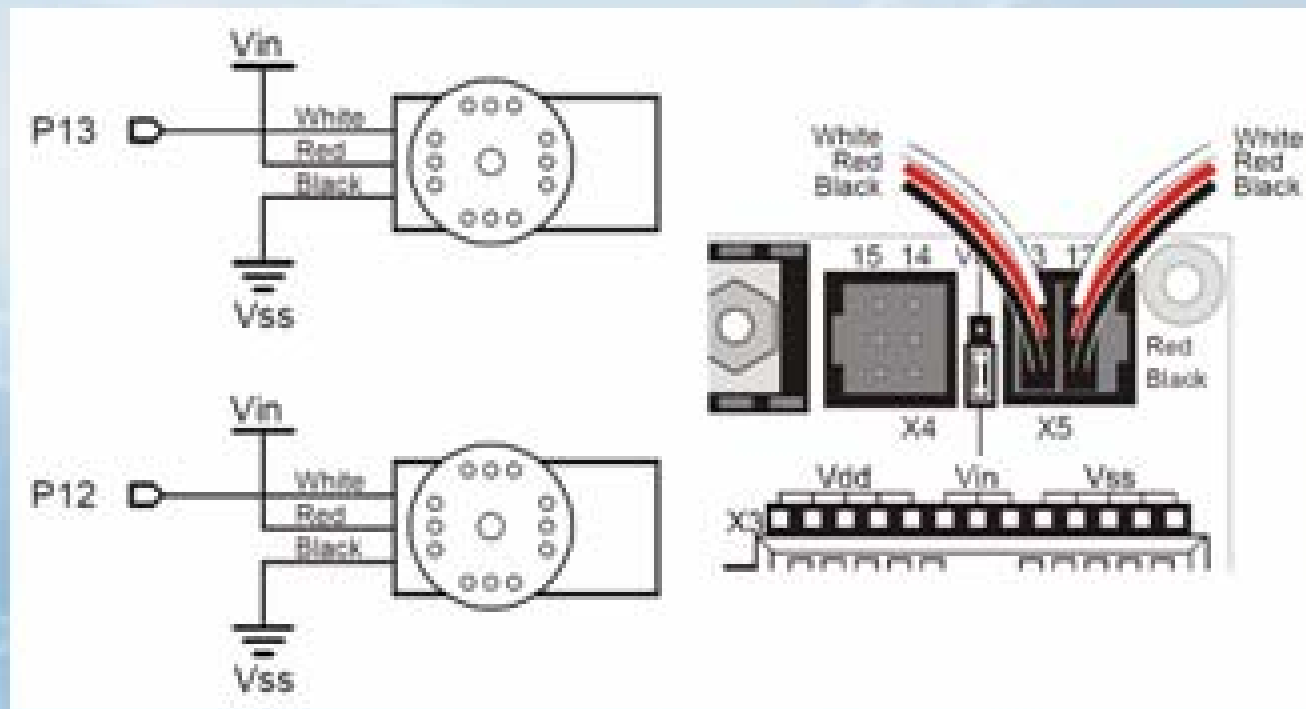

Page 61



Centering the Servos

Example Program: CenterServoP12.bs2

```
* Robotics with the Boe-Bot - CenterServoP12.bs2
* This program sends 1.5 ms pulses to the servo connected to
* P12 for manual centering.

* ($STAMP BS2)
* ($PBASIC 2.5)

DEBUG "Program Running!"

DO
  PULSOUT 12, 750
  PAUSE 20
LOOP
```

Page 69

Example Program: CenterServoP13.bs2

```
* Robotics with the Boe-Bot - CenterServoP13.bs2
* This program sends 1.5 ms pulses to the servo connected to
* P13 for manual centering.

* ($STAMP BS2)
* ($PBASIC 2.5)

DEBUG "Program Running!"

DO
  PULSOUT 13, 750
  PAUSE 20
LOOP
```

Page 70



Centering the Servos

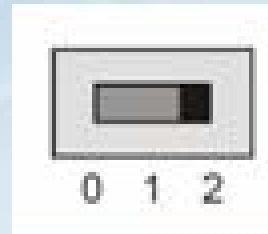

Page 68

Make the servo stop turning – use the screwdriver.

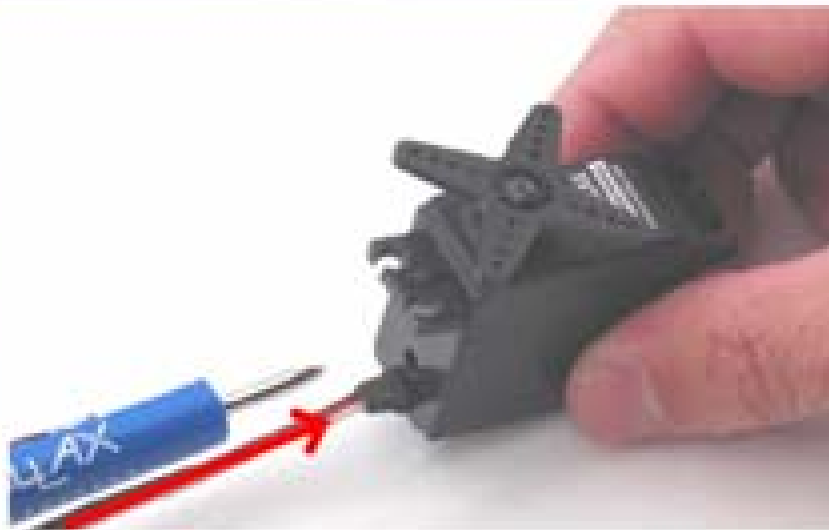

Insert tip of Phillips screwdriver into potentiometer access hole.



Gently turn screwdriver to adjust potentiometer

Page 69

Slide 7



Testing the Servos



Page 67

```
DO
  PULSOUT 12, 750
  PAUSE 20
LOOP
```

Page 69

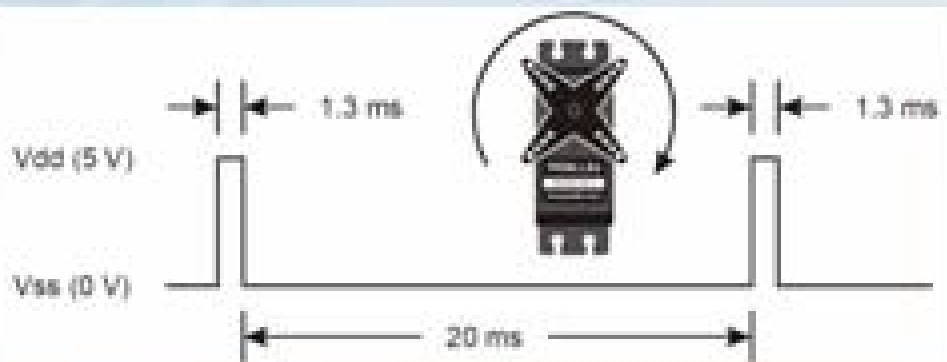

Page 76

```
DO
  PULSOUT 12, 650
  PAUSE 20
LOOP
```

Page 77

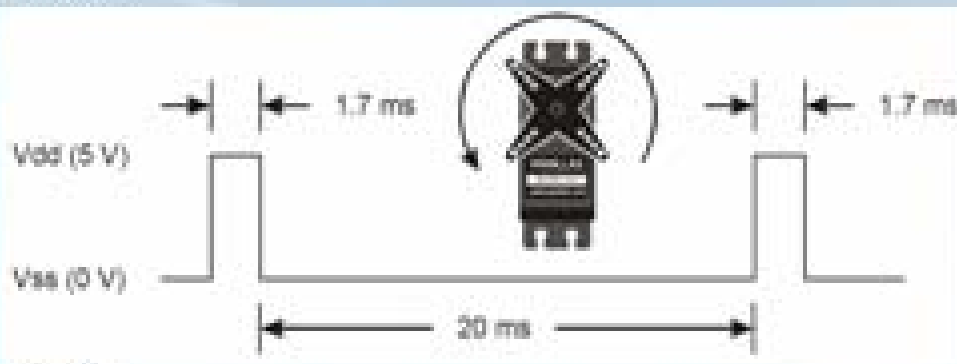

Page 78

```
DO
  PULSOUT 12, 850
  PAUSE 20
LOOP
```

Page 79

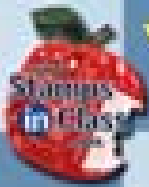

Your Turn – Adjusting the Speed and Direction

```
DO
  PULSOUT 13, 850
  PULSOUT 12, 650
  PAUSE 20
LOOP
```



Page 79

Page 81

Table 2-1: PULSOUT Duration Combinations

| Durations | | Description | Behavior |
|-----------|-----|---|----------|
| P13 | P12 | | |
| 850 | 650 | Full speed, P13 servo counterclockwise, P12 servo clockwise | |
| 650 | 850 | | |
| 850 | 850 | | |
| 650 | 650 | | |
| 750 | 850 | | |
| 650 | 750 | | |
| 750 | 750 | Both servos should stay still because of the centering adjustments you made in Activity #4. | |
| 760 | 740 | | |
| 770 | 730 | | |



Testing the Servos



Page 67

```
DO
  PULSOUT 12, 750
  PAUSE 20
LOOP
```

Page 69

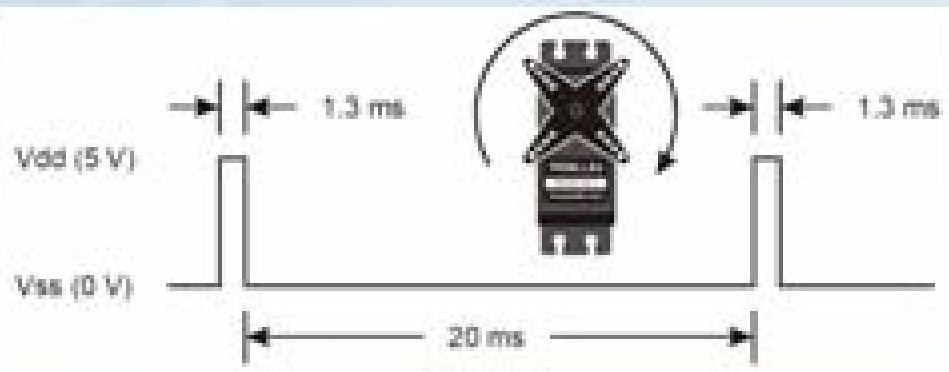

Page 76

```
DO
  PULSOUT 12, 650
  PAUSE 20
LOOP
```

Page 77



Page 78

```
DO
  PULSOUT 12, 850
  PAUSE 20
LOOP
```

Page 79



How the Assembly Instructions Work



Mounting the Topside Hardware

- ✓ Start by gathering this list of parts.
- ✓ Then, follow the accompanying instructions.

Parts List:

See Figure 3-2.

- (1) Boe-Bot chassis
- (4) 1" Standoffs
- (4) Pan head screws, 1/4" 4-40
- (1) Rubber grommet, 13/32"

Instructions:

- ✓ Insert the 13/32" rubber grommet into the hole in the center of the Boe-Bot chassis.
- ✓ Make sure the groove in the outer edge of the rubber grommet is seated on the edge of the hole in the chassis.
- ✓ Use the four 1/4" 4-40 screws to attach the four standoffs to the chassis as shown.



Figure 3-2
Chassis and
Topside
Hardware

Parts (left):
assembled
(right).

Page 92 – 93

Before → After



Assembling the Boe-Bot...Finished

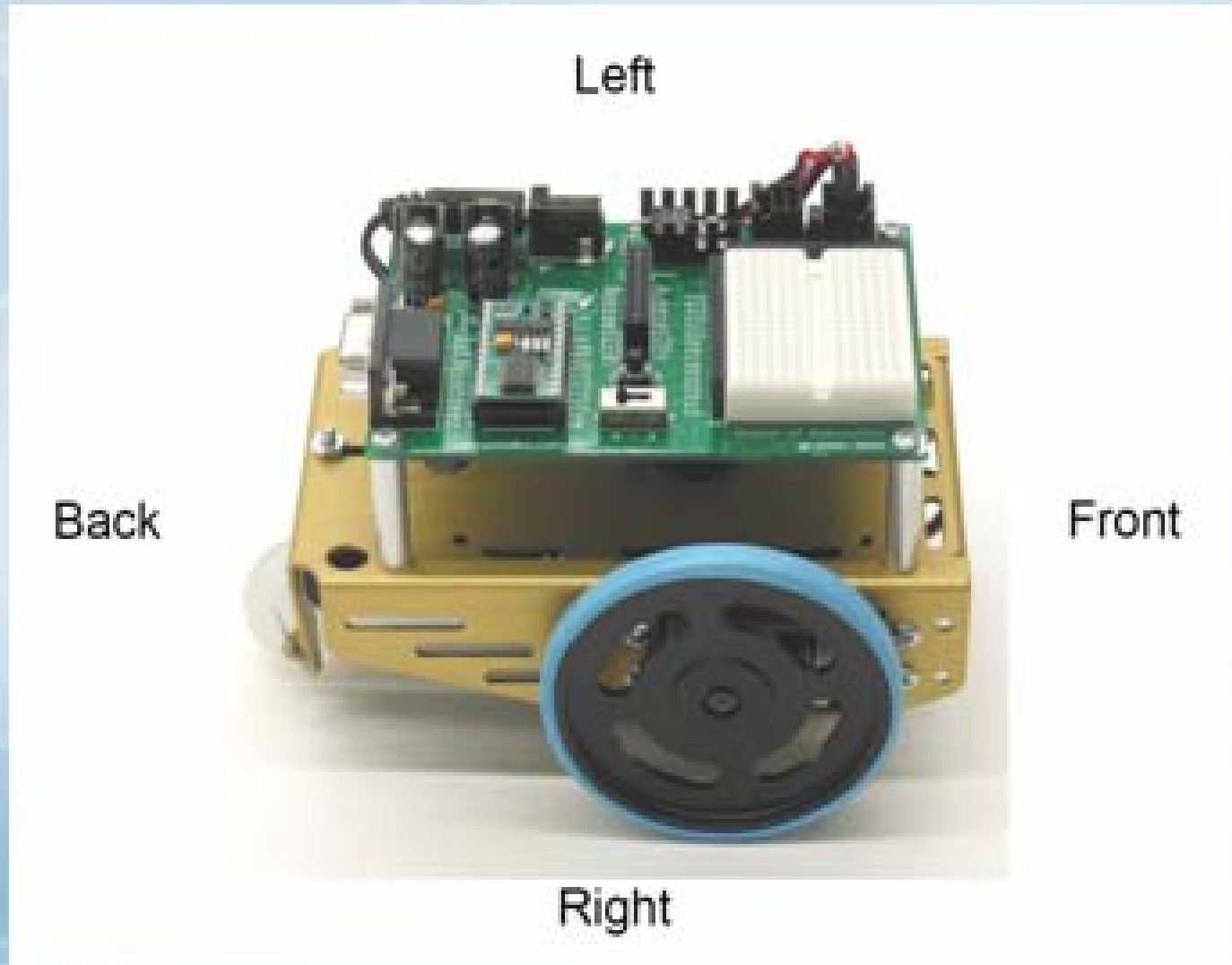



Retest the Servos

```
' ($STAMP BS2)
' ($PBASIC 2.5)

DEBUG "Program Running!"

counter          VAR          Word

FOR counter = 1 TO 122
  PULSOUT 12, 650
  PAUSE 20
NEXT

FOR counter = 1 TO 40
  PULSOUT 12, 750
  PAUSE 20
NEXT

FOR counter = 1 TO 122
  PULSOUT 12, 850
  PAUSE 20
NEXT

END
```

Page 103



Build the Start/Reset Indicator

✓ Brownout

- Batteries drop below 5.2 V
- Brownout detector circuit resets the BASIC Stamp
- Program starts over from beginning

✓ Low Battery Indicator

- Add speaker to Boe-Bot
- "Beep" first thing in program
 - ✓ If Boe-Bot beeps during navigation, must have reset
 - ✓ Thus batteries are low



Start Reset Indicator Circuit and Program



Page 107

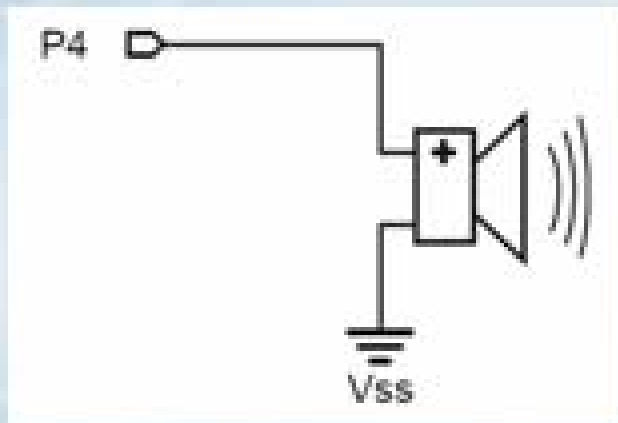

Page 108

FREQOUT *Pin, Duration, Freq1 {,Freq2}*

FREQOUT 4, 2000, 3000

Page 109

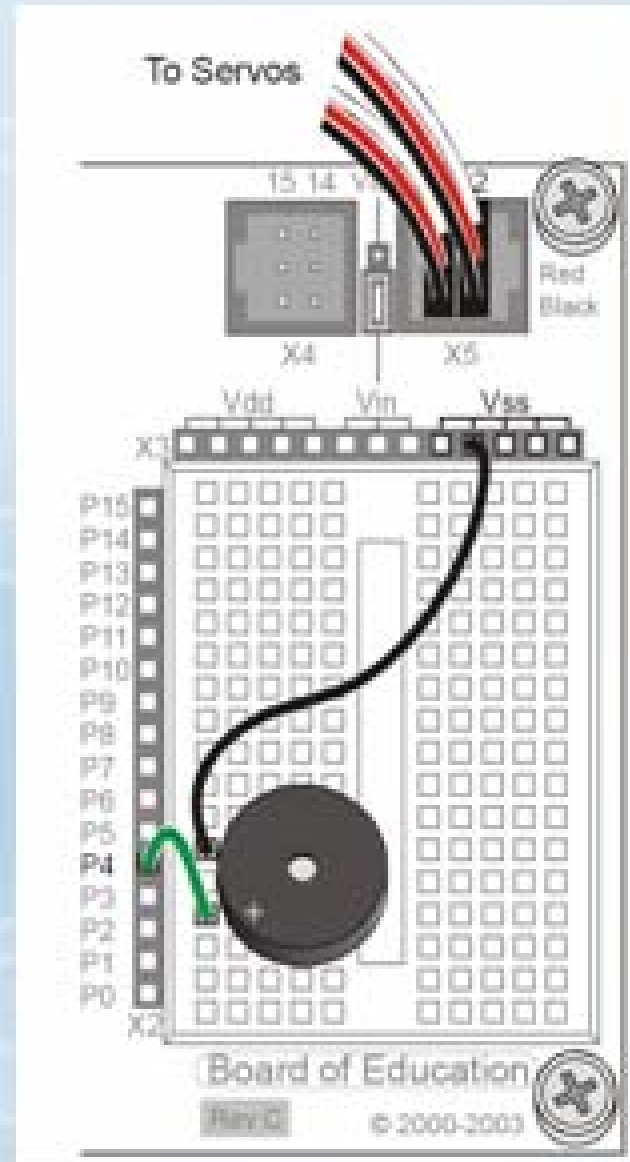

Page 108