

Resistance Measurements Using the Wheatstone Bridge

Purpose: 1. To become familiar with the operation of a slide-wire Wheatstone bridge.
2. To verify the equation for series and parallel equivalent resistances.

Equipment: Slidewire Wheatstone bridge, galvanometer, power supply, decade resistance box, unknown resistances.

Introduction: The standard Wheatstone bridge circuit is shown in the diagram. This configuration, when properly used, allows us to make very accurate determinations of unknown resistances. The method consists of adjusting the ratio R_A/R_B (by moving point **a**) or adjusting the variable resistor R (or both) until no current flows through the galvanometer.

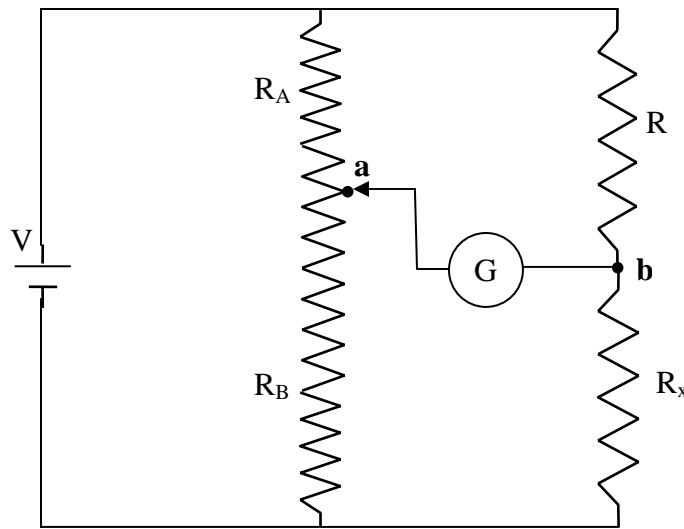

When a null reading is found on the galvanometer, the potential difference between points **a** and **b** is zero. It can then be shown that

$$R_x = \frac{R_B}{R_A} R \quad \dots\dots\dots (1)$$

On the slidewire-type Wheatstone bridge, the resistances R_A and R_B consist of simply a long wire of uniform cross section. The ratio R_A/R_B is adjusted by moving a sliding contact (point **a** in the circuit diagram) up and down the length of the wire. Since the wire has uniform cross section, the ratio R_B/R_A is equivalent to L_B/L_A where L_A and L_B are the respective lengths of R_A and R_B . Thus equation 1 becomes

$$R_x = \frac{L_B}{L_A} R \quad \dots\dots\dots(2)$$

Procedure:

Note: The galvanometer is a very sensitive and delicate current measurement device. When first being used in a circuit connections should only be made briefly by using the tap switch.

1. Go through the derivation of equation 1 and include it as part of your lab report.
2. Set up the circuit for the Wheatstone bridge. Have your instructor check your setup before continuing. Set the power supply between one and two 2 volts.
3. In the following measurements you should proceed as follows; gently and briefly tap the switch to roughly see how large a current is flowing through the galvanometer. By adjusting either R_B/R_A or by changing R (or both), gradually reduce the reading on the galvanometer until you obtain a null (zero) reading. At this point we say that the Wheatstone bridge is balanced and the unknown resistance, R_x , can be calculated from the above equation (2).
4. Measure the four resistors on the resistor board individually and calculate the equivalent resistance of all four in series. Do the same for all four resistances in parallel.
5. Now connect the four resistor in series and measure the combined resistance using your Wheatstone bridge circuit. Find the percent difference between this value and that obtained in part 4.
6. Connect the four resistors in parallel and measure the combined resistance using your Wheatstone bridge circuit. Find the percent difference between this value and that obtained in part 4 for the parallel equivalent resistance.